



# BEVERAGE-AIR

Project: _____	AIA#
Item: _____	
Location: _____	SIS#
Approved: _____	

## TOP MOUNT REACH-IN REFRIGERATOR

TMR2HC Reach-In Refrigerator  
Hydrocarbon Series

MODEL:  
TMR2HC-1S

TMR2HC TOP MOUNT REACH-IN REFRIGERATOR

**2 Year Parts / Labor Warranty**

**Additional 5 Year Compressor Warranty**



### CABINET CONSTRUCTION

- Intelligent temperature control reduces energy consumption
- Three (3) shelves per section
- Door locks
- Stainless steel exterior and interior
- Easy access to the refrigeration system
- 6" Heavy-duty casters, two (2) with brakes
- Energy efficient LED lights
- Fans are positioned to increase internal capacity
- Fill mark helps to prevent overpacking



### ACCESSORIES

- Additional shelves

### REFRIGERATION SYSTEM

- Uses environmentally friendly, energy efficient R290 refrigerant, and meets all regulatory requirements for CARB, SNAP, DOE & more
- Hot gas condensate evaporator
- Coated evaporator coil
- Maintains product temperatures between 36°F and 38°F



Please verify qualifying units by visiting:  
[www.energystar.gov/cfs](http://www.energystar.gov/cfs)

3779 Champion Blvd., Winston-Salem, NC 27105  
1-888-845-9800 Fax: 1-336-245-6453  
Beverage-Air.com Sales@bevair.com



# BEVERAGE-AIR

MODEL	TMR2HC-1S
<b>EXTERNAL DIMENSIONAL DATA</b>	
Width Overall	53 3/16"
Depth Overall	33 9/16"
Height Overall	80 1/2"
Number of Doors	2
<b>INTERNAL DIMENSIONAL DATA</b>	
NET Capacity (cubic ft.)	40
Internal Width Overall (in)	50 7/32"
Internal Depth Overall (in)	28 3/32"
Internal Height Overall (in)	56 5/32"
Number of Shelves	6
<b>ELECTRICAL DATA</b>	
Full Load Amperes 115/60/1	5.3
<b>REFRIGERATION DATA</b>	
Horsepower	1/2
Capacity (BTU/Hr)	3251
Heat Rejection (BTU/Hr)	4877
Charge (lbs/grams)	0.1984/90
<b>SHIPPING DATA</b>	
Gross Weight (crated lbs)	646 lbs
Height - Crated	81"
Width - Crated	56"
Depth - Crated	35"

## Top Mount Reach-In Refrigerator Model: TMR2HC-1S

### Model Views

Required Clearance: Top 12", Rear 3", Side 0"

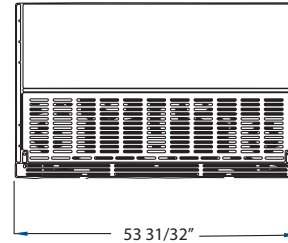

### PLAN VIEW

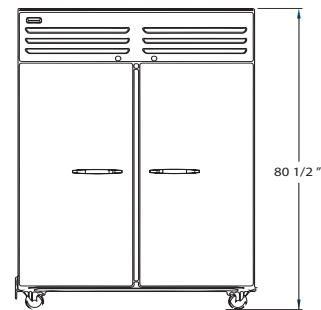

### ELEVATION VIEW

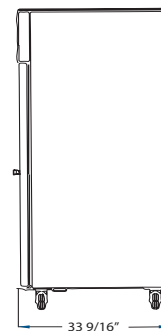

### SIDE VIEW

### ELECTRICAL CONNECTION



115/60/1  
NEMA 5-15P

Unit pre-wired at factory and include 9.8' long cord and plug set.

